



MEMO

Date: May 3, 2023

RE: Electric Underground Requirements

To Whom It May Concern:

In an effort to streamline our trenching, meter and underground installations for new, remodel, or replacement meter projects, we are providing a copy of Bandon Electric's Undergrounding Requirements for your reference. The purpose is to provide safety for your contractors and our linemen when connecting the electric meter to the grid.

We do understand that not every service installation can be installed to the requirements, but this should be a rare exception. Any deviation must be approved by Bandon Electric in writing prior to any work being performed or as soon as it becomes apparent that a deviation is required. Please contact Jim Wickstrom, Electric Supervisor at electric@cityofbandon.org.

Should a nonconformity be found at the time of the service inspection, and no prior approval has been provided for the deviation, the City will not connect the service. The nonconformity must be corrected prior to reinspection and connection to the electric grid.

Our standard can be found on the Electric Department's web page:
<https://www.cityofbandon.org/electric>. Any updates to the requirements will be posted there.

Thank you for following the requirements when you are working in Bandon Electric's service area. If you have any questions, you can reach me by email at drussell@cityofbandon.org or by telephone at 541-347-2437, ext. 224.

Sincerely,

A handwritten signature in cursive script that reads "Denise Russell".

Denise Russell
Utilities Office Manager

**ACKNOWLEDGEMENT
OF
ELECTRIC UNDERGROUND REQUIREMENTS**

The homeowner / contractor acknowledges the receipt of the City of Bandon's Electric Underground Requirements and agrees to install the electric service according to the requirements.

Service Address: _____

Printed Name: _____

Signature: _____

Date: _____

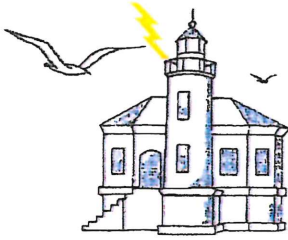

BANDON ELECTRIC TRENCH REQUIREMENTS

- Call 811 or go to Oregon Utility Notification Center to have existing utilities marked.
- All conduit should be at least schedule 40.
- 12" separation for all other ducts from electric ducts.
- Conduit installed from meter base to electric source has a trench depth of 36".
- Red warning tape needs to be installed 8"-12" below finished grade.
- A minimum of 24" radius bends on secondary conduit.
- A minimum of 36" radius bends for primary conduit.
- 3" conduit required for residential homes to electric meter.
- 4" conduit required for all three phase services.
- No more than 270 degrees of bends in any single run of conduit.
- Install pulling string in all conduit runs.
- Call 541-347-2437 for an inspection before backfilling.
- Trench to be backfilled with clean fill material.

TRENCH CROSS SECTION:

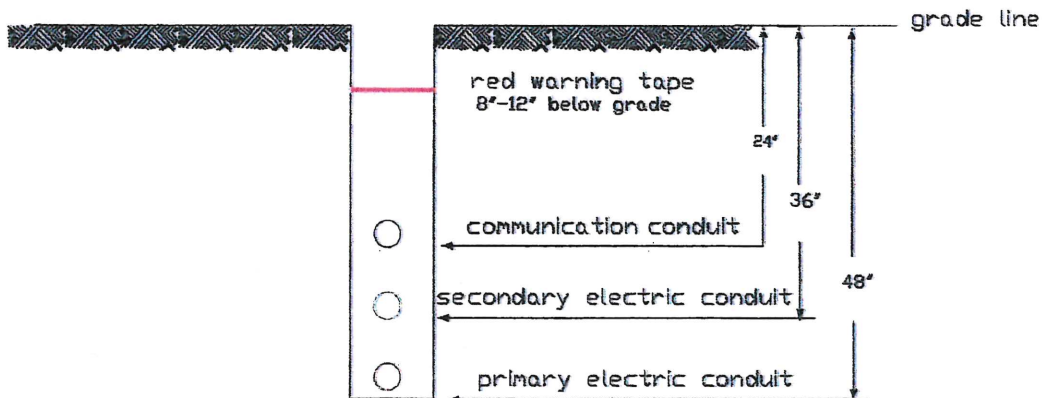

LEGEND

BANDON POWER WILL FURNISH:

- (A) METER
- (B) SERVICE LATERAL CONDUCTORS

MEMBER WILL PROVIDE:

- ① APPROVED UNDERGROUND METER BASE
- ② CONDUIT – 2" OR 3" (200A) SCH. 40 IMT OR RGS
- ② CONDUIT – 3" (320A) SCH. 40 IMT OR RGS
- ③ TRENCH – BACKFILL & 3" PVC CONDUIT
- ④ REDUCING FITTING 3" TO 2" (WHEN NEEDED)

EXTERIOR METHOD

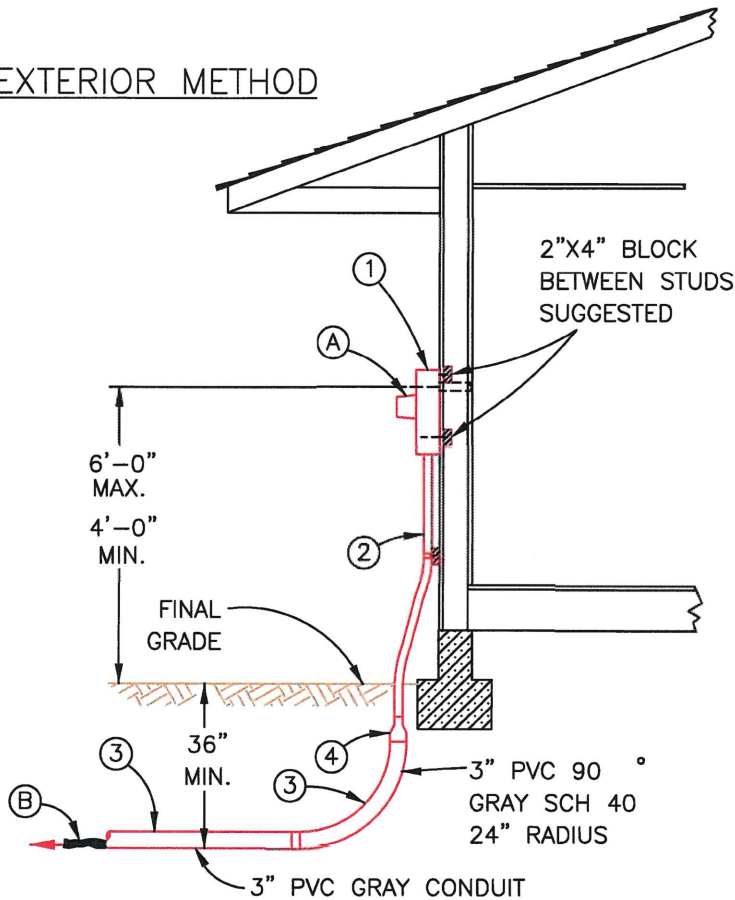

RECESSED METHOD

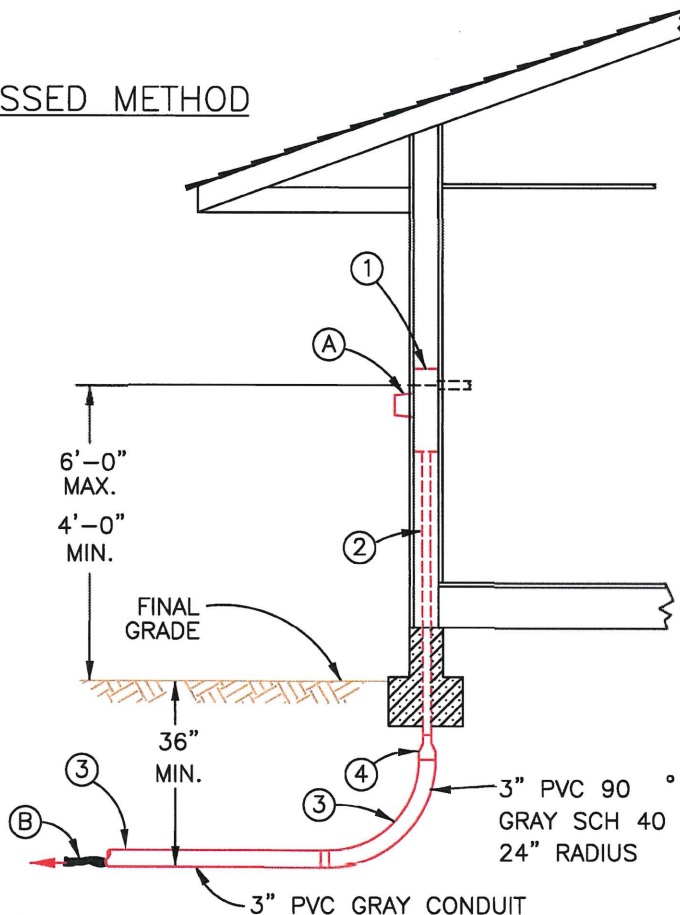

NOTES

1. ELECTRICAL LABEL OR PERMIT MUST BE DISPLAYED ON SERVICE PANEL OR METER BASE.
2. METER BASE AND CONDUIT MUST BE SECURELY ATTACHED TO STRUCTURE.
3. SOCKET MUST BE PLUMB AND SWITCH BOX MUST BE COVERED WHEN INSPECTED.
4. FOR 200A OR SMALLER SERVICES, BANDON POWER WILL TERMINATE THE SERVICE LATERAL ON THE LINE-SIDE TERMINALS OF THE MEMBER'S METER SOCKET, PROVIDED THE CUSTOMER'S RACEWAY IS A MINIMUM OF 2 INCHES.
5. CUSTOMER TO SUPPLY A 3" TO 2" REDUCING SLEEVE FROM THE 3" ELBOW TO THE 2" SERVICE ENTRANCE CONDUIT (WHEN NEEDED).
6. NYLON LINE TO BE PLACED IN CONDUIT TO FACILITATE PULLING SERVICE WIRE.
7. CONDUIT IS NOT TO BE COVERED UNTIL BANDON POWER HAS INSPECTED AND APPROVED INSTALLATION FOR PROPER DEPTH.
8. ALL CONDUIT JOINTS TO BE SECURELY GLUED.

METER INSTALLATION UNDERGROUND SERVICE METER ON HOUSE



ISSUE DATE:	REV:	DRN:	APPD:
05/11	2.0	MM	----

MT-07

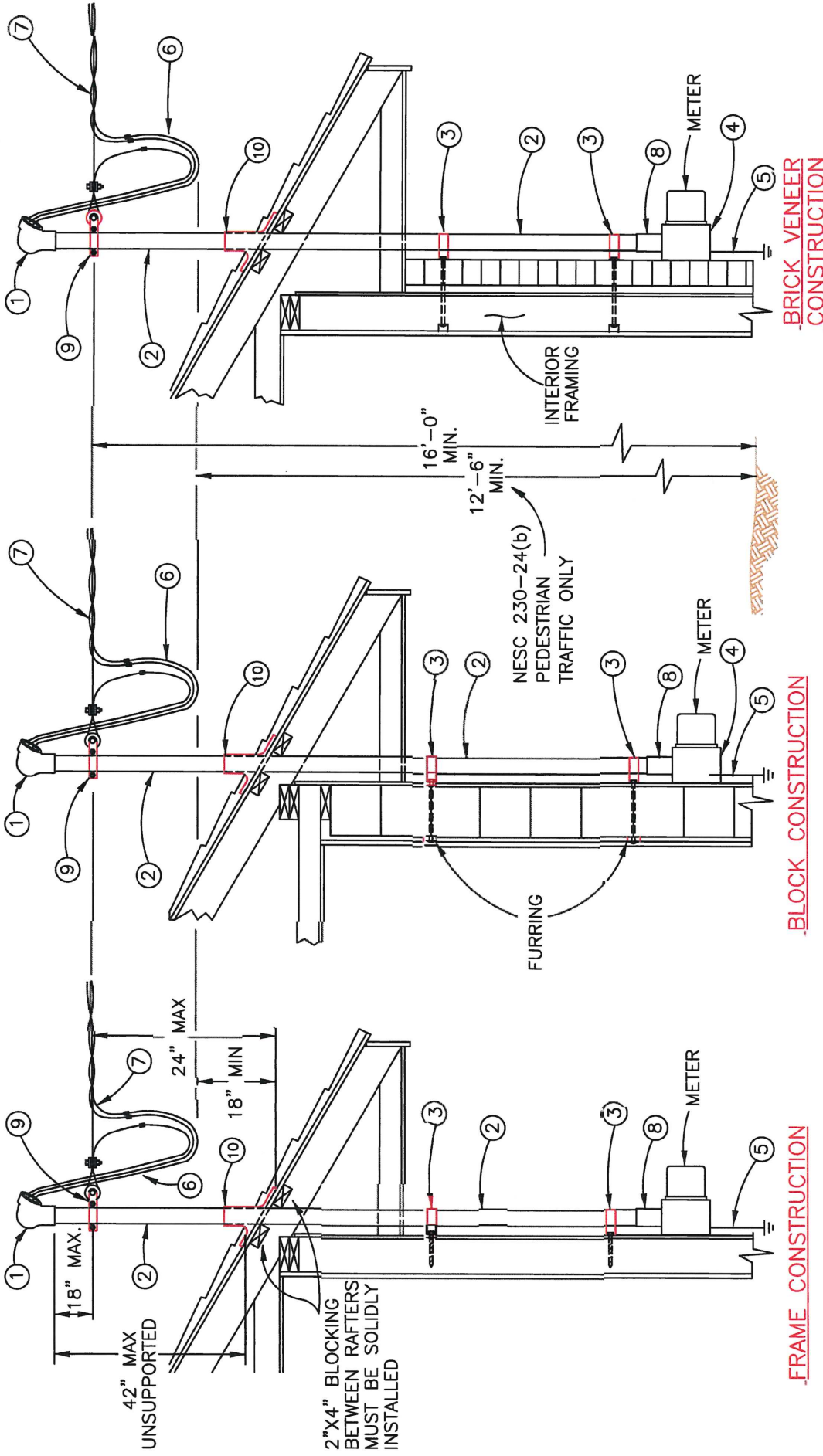

NOTES

1. IF LENGTH OF CONDUIT EXCEEDS TEN FEET, COUPLING WILL BE PERMITTED ON END ADJACENT TO METER.
2. CODE APPROVED SERVICE EQUIPMENT PROVIDED BY CUSTOMER INCLUDES: WEATHERHEAD, CONDUIT, METER BASE, GROUND ROD AND CLAMP, AND A WEATHER PROOF DISCONNECT SWITCH.
3. SINGLE PHASE SHOWN - THREE PHASE SIMILAR

LEGEND

- | | |
|--------------------------------|-------------------------------------|
| ① WEATHERHEAD | ⑥ CUSTOMER WIRES WITH 24" LEADS |
| ② CONDUIT, SERVICE MAST | ⑦ BANDON POWER WIRES AND CONNECTION |
| ③ STRAPS, CONDUIT | ⑧ ADAPTER, LOCKING RING, BUSHING |
| ④ METER BASE | ⑨ BANDON POWER HARDWARE |
| ⑤ GROUND WIRE (#4 Cu OR #6 Cu) | ⑩ SHEET METAL OR PIPE FLASHING |

**METER INSTALLATION
OVERHEAD SERVICE
METER ON HOUSE**

	ISSUE DATE:	REV:	DRN:	APPD:
	05/11	2.0	MM	----
DWG:				MT-05

200 AMP METERBASE ON POST STANDARD

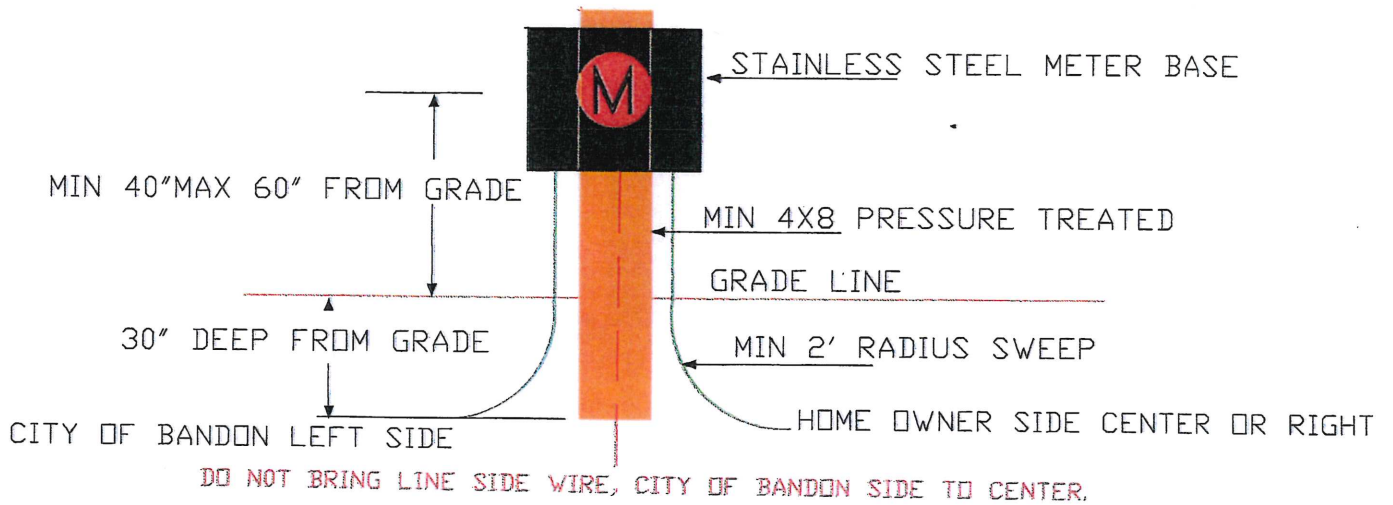

NOTES

1. CONDUIT QUANTITIES AND STUB-OUT LOCATIONS MAY VARY DEPENDING ON FACILITIES LAYOUT. CONDUIT QUANTITIES AND STUB-OUT LOCATIONS SHALL BE APPROVED BY A BANDON POWER REPRESENTATIVE PRIOR TO THE VAULT INSTALLATION.

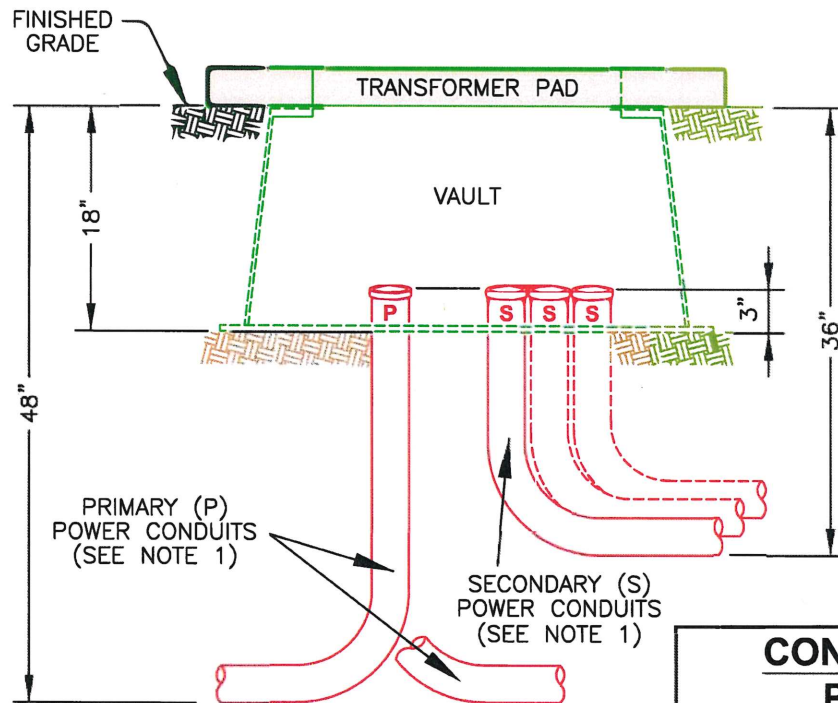
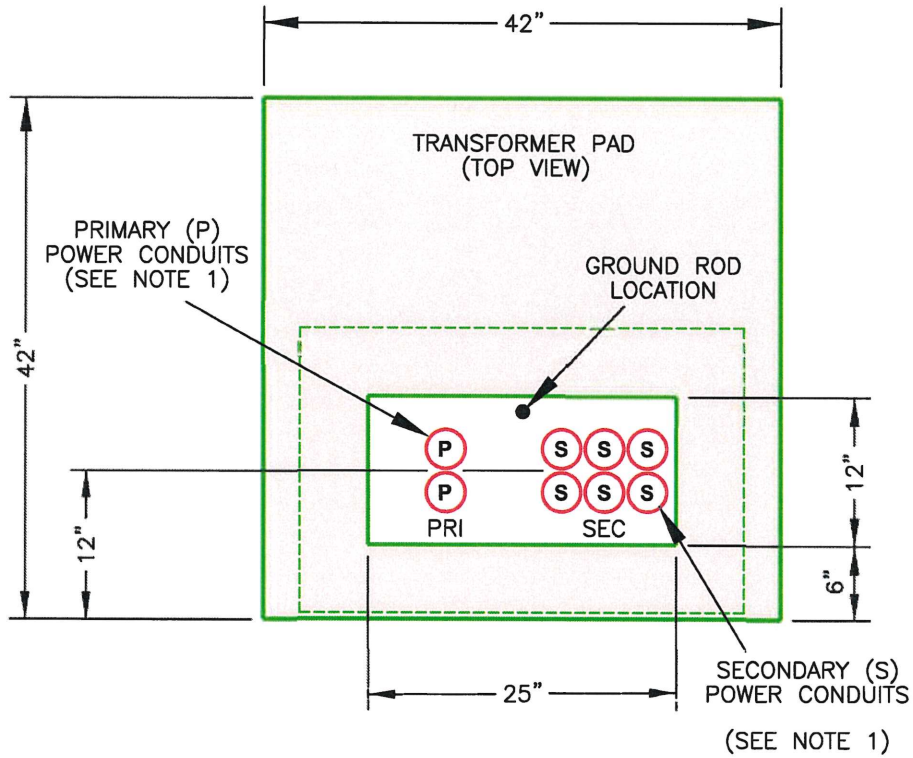

PADMOUNT TRANSFORMER

SINGLE PHASE
PADMOUNT TRANSFORMER
CONDUIT LAYOUT

**CONDUIT LAYOUT
PADMOUNT
TRANSFORMER**



ISSUE DATE:	REV:	DRN:	APPD:
05/11	2.0	MM	----

CL-01

NOTES

1. CONDUIT QUANTITIES AND STUB-OUT LOCATIONS MAY VARY DEPENDING ON FACILITIES LAYOUT. CONDUIT QUANTITIES AND STUB-OUT LOCATIONS SHALL BE APPROVED BY A BANDON POWER REPRESENTATIVE PRIOR TO THE VAULT INSTALLATION.

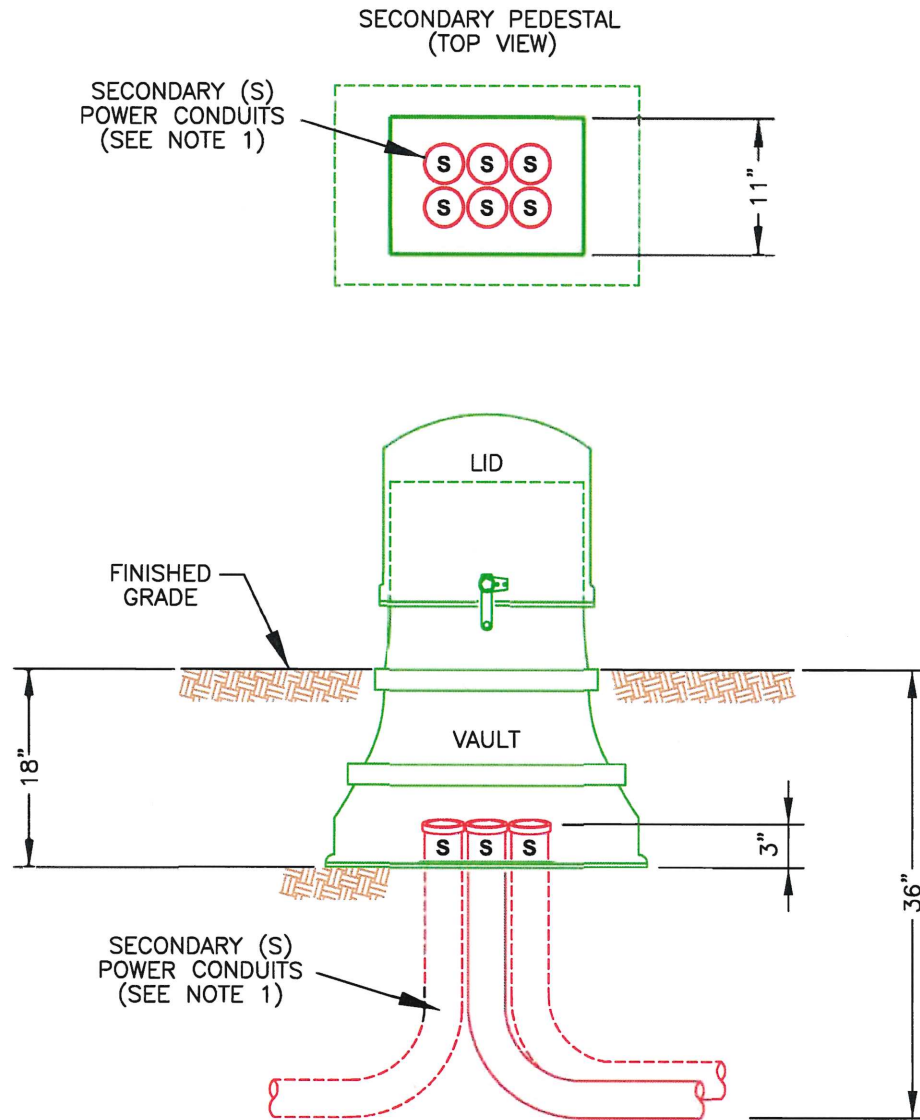

SECONDARY PEDESTAL

SINGLE PHASE
SECONDARY PEDESTAL
CONDUIT LAYOUT

CONDUIT LAYOUT
SECONDARY
PEDESTAL



ISSUE DATE: 05/11	REV: 2.0	DRN: MM	APPD: ----
----------------------	-------------	------------	---------------

CL-02

NOTES

1. CONDUIT QUANTITIES AND STUB-OUT LOCATIONS MAY VARY DEPENDING ON FACILITIES LAYOUT. CONDUIT QUANTITIES AND STUB-OUT LOCATIONS SHALL BE APPROVED BY A BANDON POWER REPRESENTATIVE PRIOR TO THE VAULT INSTALLATION.

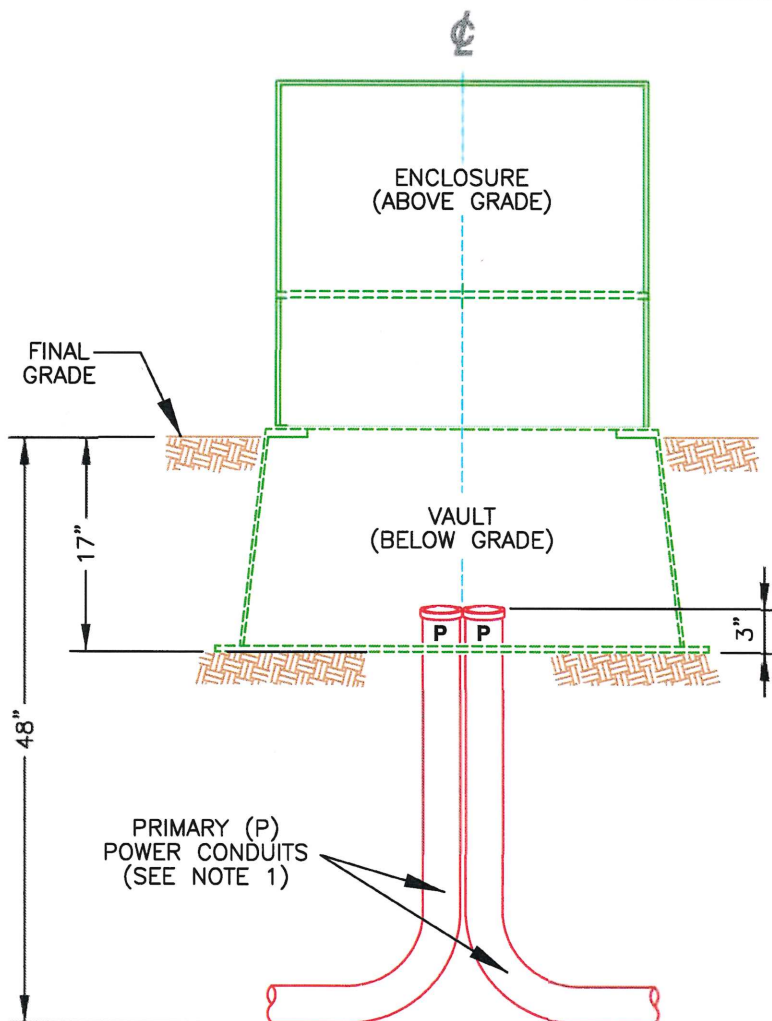
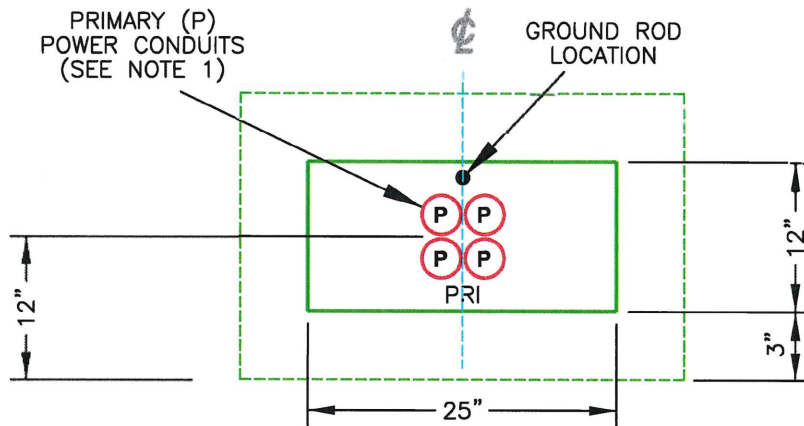

CONDUIT LAYOUT-SINGLE PHASE SECTIONALIZING ENCLOSURE



ISSUE DATE:	REV:	DRN:	APPD:
05/11	2.0	MM	----

CL-03

FIBERGLASS GROUND SLEEVE INSTALLATION

Ground Sleeve Installation

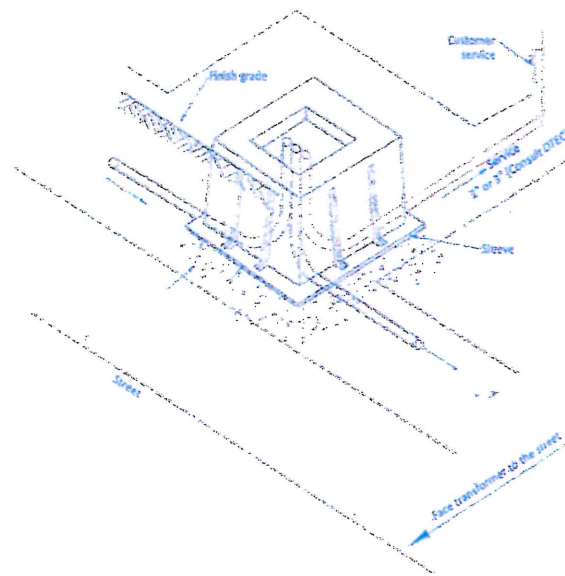

Attention: Stub outs should be a minimum 10 feet beyond edge of sleeve and ends marked with fiberglass underground marker posts.

PAD-MOUNTED TRANSFORMER CLEARANCES

Pad-Mounted Transformer Minimum Clearance Requirements

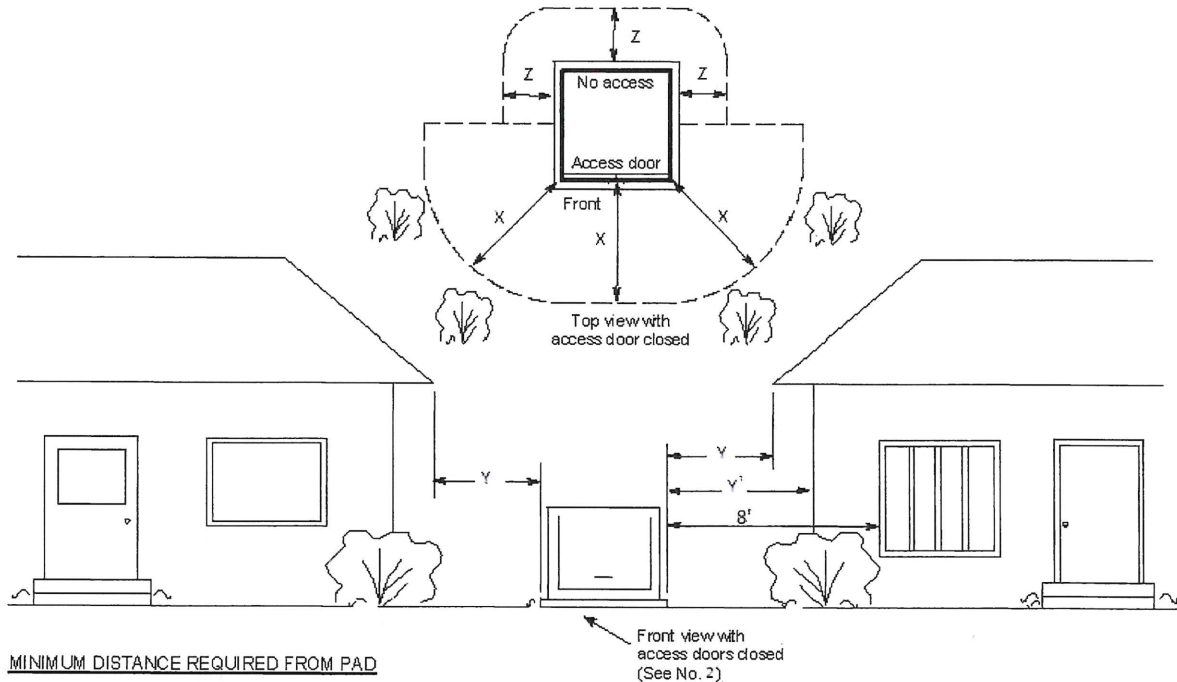

MINIMUM DISTANCE REQUIRED FROM PAD

x = 10 ft. clear area in front of any equipment access door or opening to allow the use of hot sticks
(See dimensions in the drawing above and in requirement 1 below)

y = 8 ft. from any structure or roof overhang consisting of combustible material.
y' = 3 ft. to non-combustible structures having no openings closer than 10 ft.

z = 3 ft. clear area on non-access sides of the equipment to allow work space. See dimensions in the drawing above.

NOTES:

1. Consult OREGON ADMINISTRATIVE RULES 814-22-700 (electrical specialty code) and local building and fire codes for more consumer information.
2. Front of pad-mounted transformer to be located away from building walls or other barriers to allow for safe working practices. If front of transformer must face wall, allow "x" dimension for working area.
3. Consult utility for additional clearances that maybe required to building doors, windows, fire escapes, and air vents, etc.
4. Where pad-mounted transformers or other equipment is installed in a location where it might be stuck by a motorized vehicle the consumer is to install and maintain City of Bandon approved barrier posts to protect the equipment.

City of Bandon

Electric Meter Base Types

Manufacturer: Cooper B-Line
Meter bases must be Stainless Steel

Residential

200 AMP Overhead U204
Stainless Steel Meter Base



200 AMP Underground
Flush Mount UG204(F)
Stainless Steel Meter Base

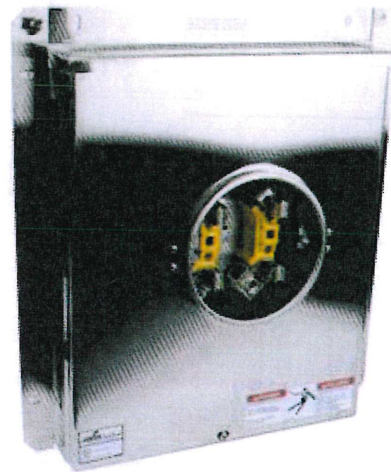

200 AMP Underground
Surface Mount UG204
Stainless Steel Meter Base



400 AMP Underground
Surface Mount 324N
Stainless Steel Meter Base

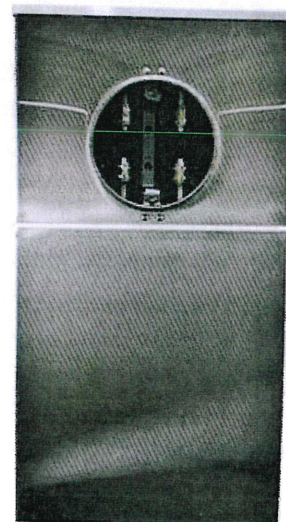

City of Bandon Electric Meter Base

Line and Load Configurations

Residential

200 AMP



CUSTOMER LOADS

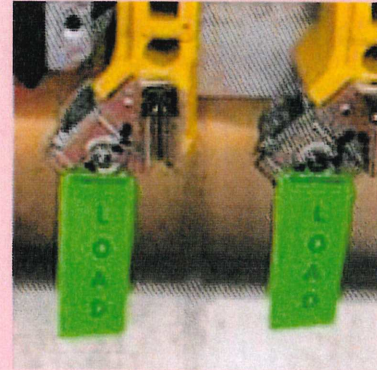

400 AMP

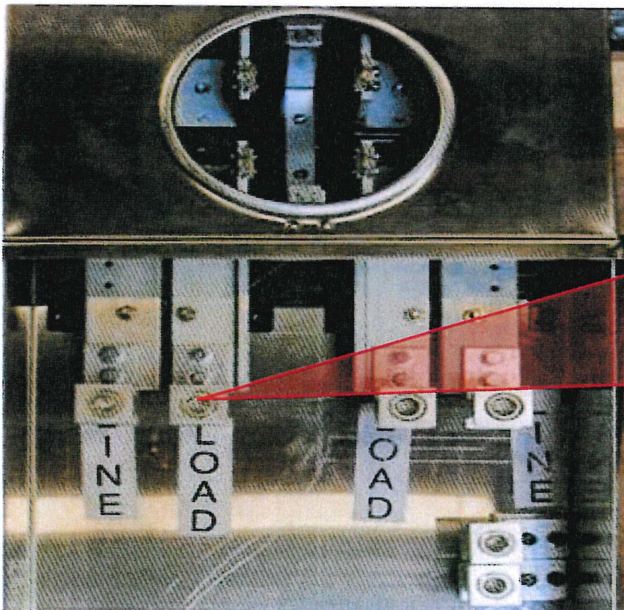

CUSTOMER LOADS



City of Bandon Electric Cabinet Types

Manufacturer: Cooper B-Line

Must be Stainless Steel

Commercial

UL Listed Rainproof Type
3R No. 244811 RTCT
Single-Phase Stainless
Steel Cabinet

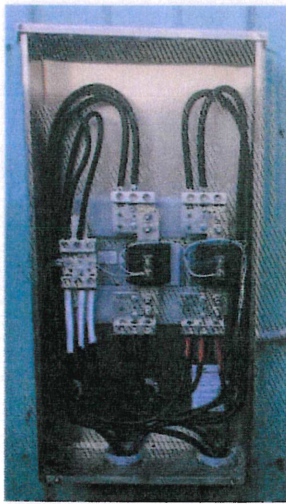

UL Listed Rainproof Type
3R No. 364811 HRTCT
Three-Phase Stainless
Steel Cabinet

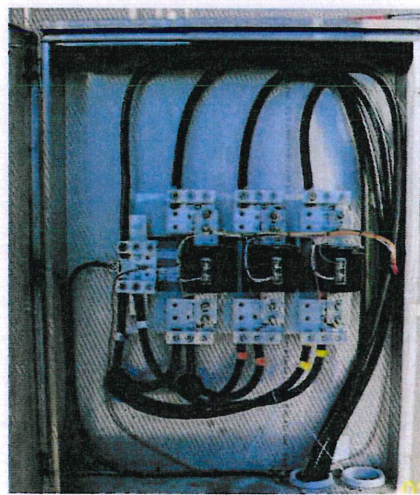

Electric Switchboard

Please see Electric Utility Service Equipment Requirements

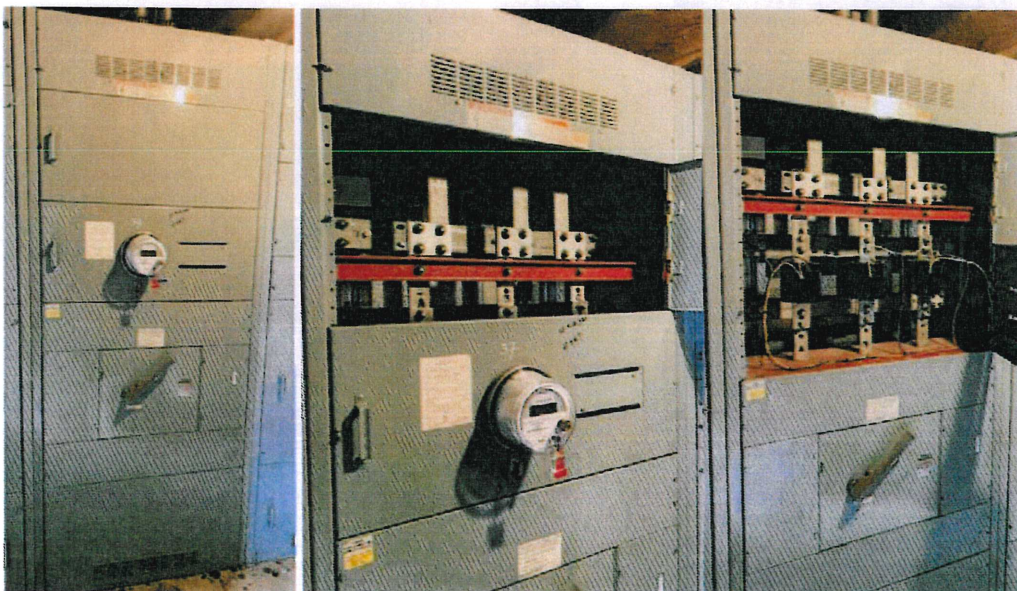

Labeling



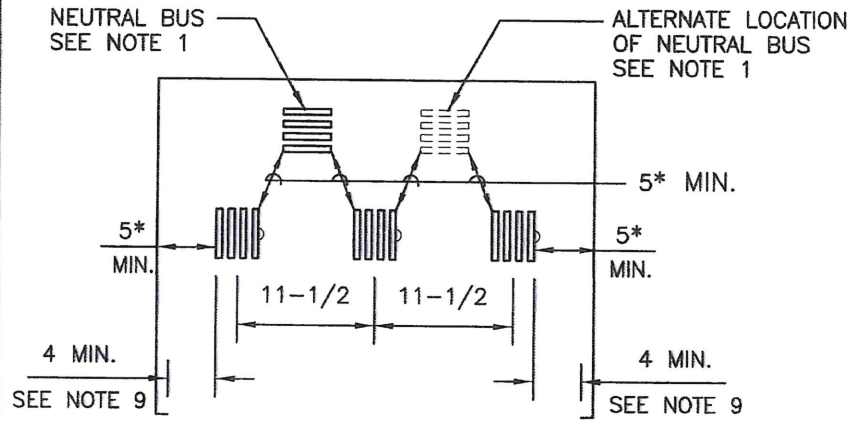

* SEE NOTE 6

TOP VIEW

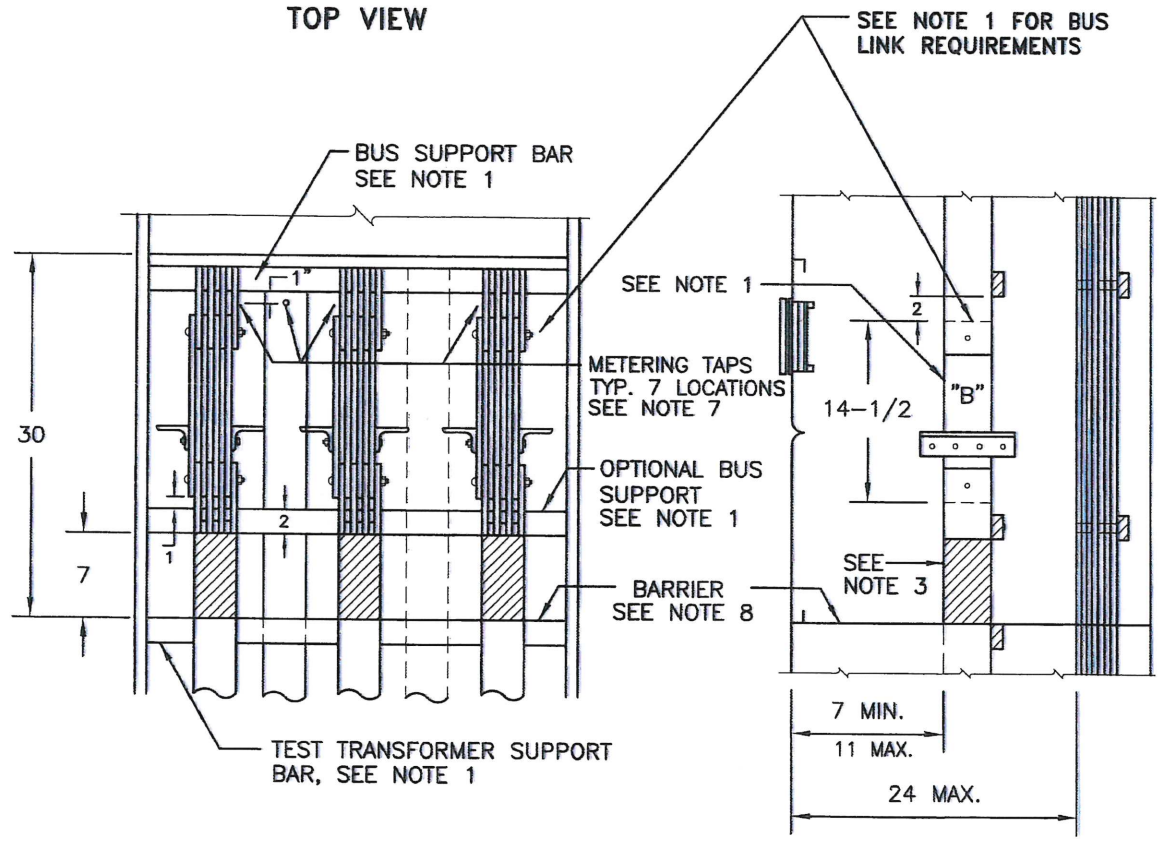

FRONT VIEW

SIDE VIEW

ALL DIMENSIONS SHOWN ARE IN INCHES

REV.	DATE	DESCRIPTION		
5	11/01	REVISED BOLT PATTERN AND NOTE 5 - PROJECT #000814 AND #001117		
SCALE N.T.S.	INSTRUMENT - TRANSFORMER COMPARTMENT FOR SWITCHBOARDS 1001-3000 AMPERES AND ABOVE, 0-600 VOLTS 3Ø 3-WIRE AND 3Ø 4-WIRE		SHT 1 OF 2	
DATE 11/01			DWG NO. 322	REV. 5
ELECTRIC UTILITY SERVICE EQUIPMENT REQUIREMENTS COMMITTEE				

NOTES:

1. Bus arrangements and supports shall be provided as shown, except the neutral bus may located at either side or on either side wall. (Note: neutral bus not required for 3-phase, 3-wire service). Bus units shall be anchored so that busses will remain in position when section "B" is removed. For details of section "B" and the insulated current-transformer support, see Drawing 330 and Drawing 331. Bus supports shall be constructed of a continuous bar of insulating material.
2. The bus units may be supplied from the top or bottom, and shall be constructed of rectangular bus. Maximum allowable bus size shall be four 1/4-inch x 4-inch bars spaced 1/4-inch.
3. Bus units shall be insulated as shown and the insulating material shall be rated for the serving voltage. Round bus corners as necessary to prevent damage to insulation.
4. When the compartment is supplied from horizontal cross-bussing, the bussing shall pass through the compartment or in the sealed area above the compartment.
5. Except for conductors supplying the instrument transformer compartment, and the ground bus, no other conductors or devices shall be installed in, or routed through, the compartment or the sealed area above the compartment. The ground bus shall not infringe on utility compartment space, or reduce any clearances. Customer connections to the ground bus shall not be allowed in the instrument transformer compartment.
6. A clear unobstructed work space shall be provided around the current-transformer bus units from the barrier to 2 inches above the removable current-transformer bus sections ("B").
7. A 10-32 tap for attachment of meter wiring shall be provided as follows:
 - a. One tap on each upper and lower phase bus unit with a 10-32 screw and washer provided for each phase bus in either the upper or lower position.
 - b. One tap on the neutral bus as shown, or when the compartment is supplied from cross-bussing a tap may be provided on the neutral cross-bus, or on a bus bar extension provided from the neutral cross-bus. A 10-32 screw and washer shall be provided for the neutral bus. Tap locations shall be centered between phase bus units, or at either side, and shall be readily accessible under energized conditions and with the current-transformers in place.
8. The barrier shall be constructed of a rigid insulating material resistant to ARC tracking and shall be secured in place with a maximum deflection of 1/2 inch from an applied force of 25 pounds downward. Openings in the barrier (i.e., peripheral gaps around barrier, cutouts around bus bars, and hole diameters provided for ventilation) shall not exceed 3/8 inch. The barrier shall be attached with nonconductive fasteners.
9. Dimension measured to inside edge of the compartment access opening.

REV.	DATE	DESCRIPTION	
5	11/01	REVISED BOLT PATTERN AND NOTE 5 - PROJECT #000814 AND #001117	
SCALE	N.T.S.	INSTRUMENT - TRANSFORMER COMPARTMENT FOR SWITCHBOARDS 1001-3000 AMPERES AND ABOVE, 0-600 VOLTS 3Ø 3-WIRE AND 3Ø 4-WIRE	SHT 2 OF 2
DATE	11/01		ELECTRIC UTILITY SERVICE EQUIPMENT REQUIREMENTS COMMITTEE

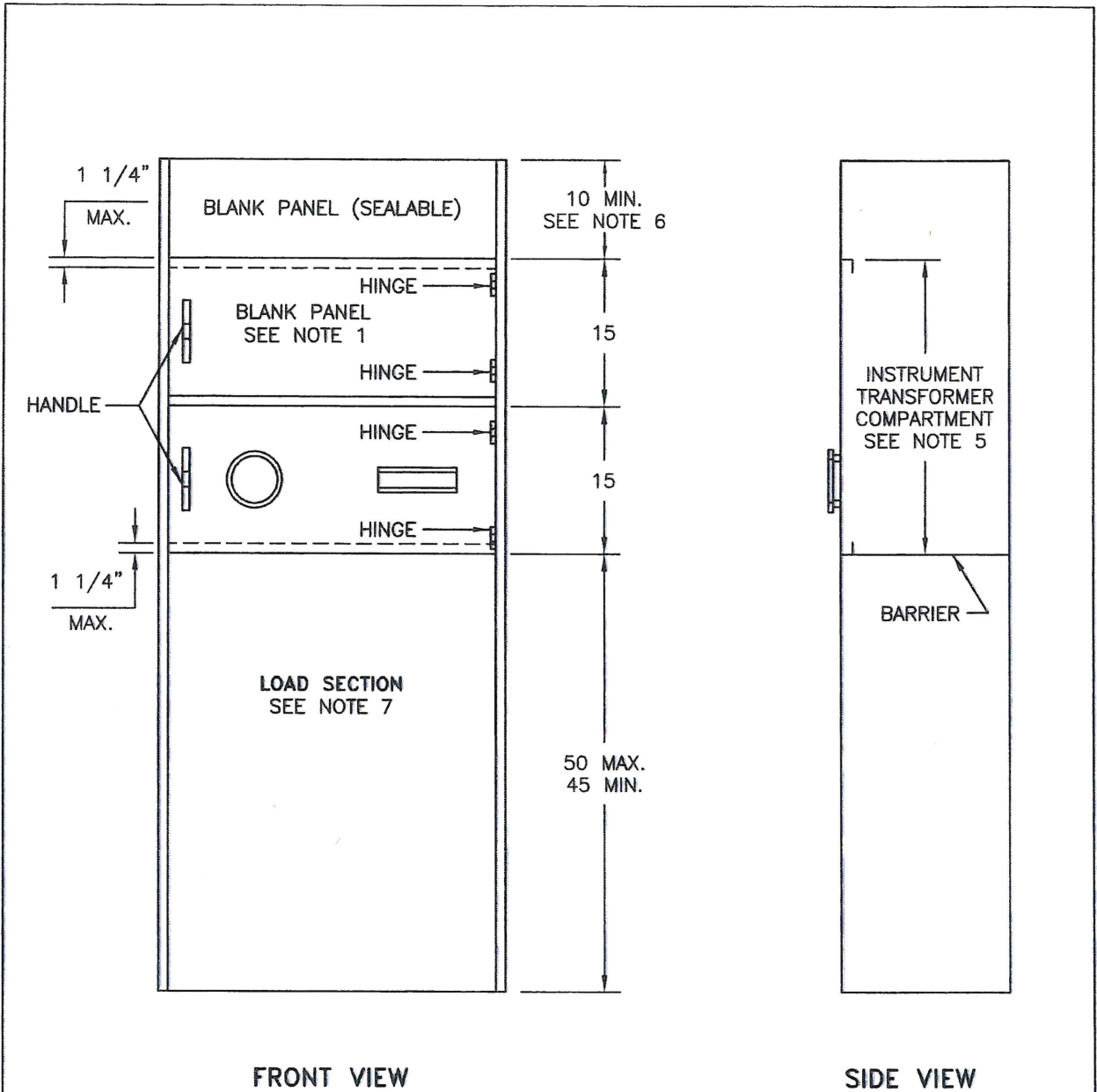

FRONT VIEW

SIDE VIEW

ALL DIMENSIONS SHOWN ARE IN INCHES

REV.	DATE	DESCRIPTION	
5	11/09	ADDED MAXIMUM DIMENSIONS FOR FLANGES	
SCALE	DATE	STANDARD SWITCHBOARD SERVICE SECTION WITH INSTRUMENT-TRANSFORMER COMPARTMENT 0-600 VOLTS	SHT 1 OF 2
N.T.S.			DWG NO. 325
DATE	05/00	ELECTRIC UTILITY SERVICE EQUIPMENT REQUIREMENTS COMMITTEE	

NOTES:

1. Socket meter panel with blank meter panel shown. Consult serving utility regarding alternate meter panel arrangements. Blank meter panel shall be constructed of 12 gauge (minimum) steel. See Drawings 332, 333 and 336 for socket meter panel details.
2. Meter panels shall be equipped with stops to prevent inward swinging beyond the front surface of the service section.
3. Hinges shall be readily interchangeable, left or right, on the job site.
4. Removable or hinged panels enclosing unmetereed bus or cable shall be sealable. See drawing 300, note II(l).
5. For requirements regarding instrument-transformer compartments, see;
 - 0 to 1000 Amperes See Drawings 319, 320
 - 1001 to 3000 Amperes See Drawings 321, 322
 - 3001 Amperes and above See Drawings 323, 324
6. Dimension may be reduced if the service section is supplied from horizontal cross-bussing or bus duct.
7. When used as a utility terminating section in a bottom-fed service section, See Drawing 327.

REV.	DATE	DESCRIPTION	
5	11/09	ADDED MAXIMUM DIMENSIONS FOR FLANGES	
SCALE N.T.S.		STANDARD SWITCHBOARD SERVICE SECTION WITH INSTRUMENT-TRANSFORMER COMPARTMENT 0-600 VOLTS	SHT 2 OF 2
DATE 05/00			ELECTRIC UTILITY SERVICE EQUIPMENT REQUIREMENTS COMMITTEE

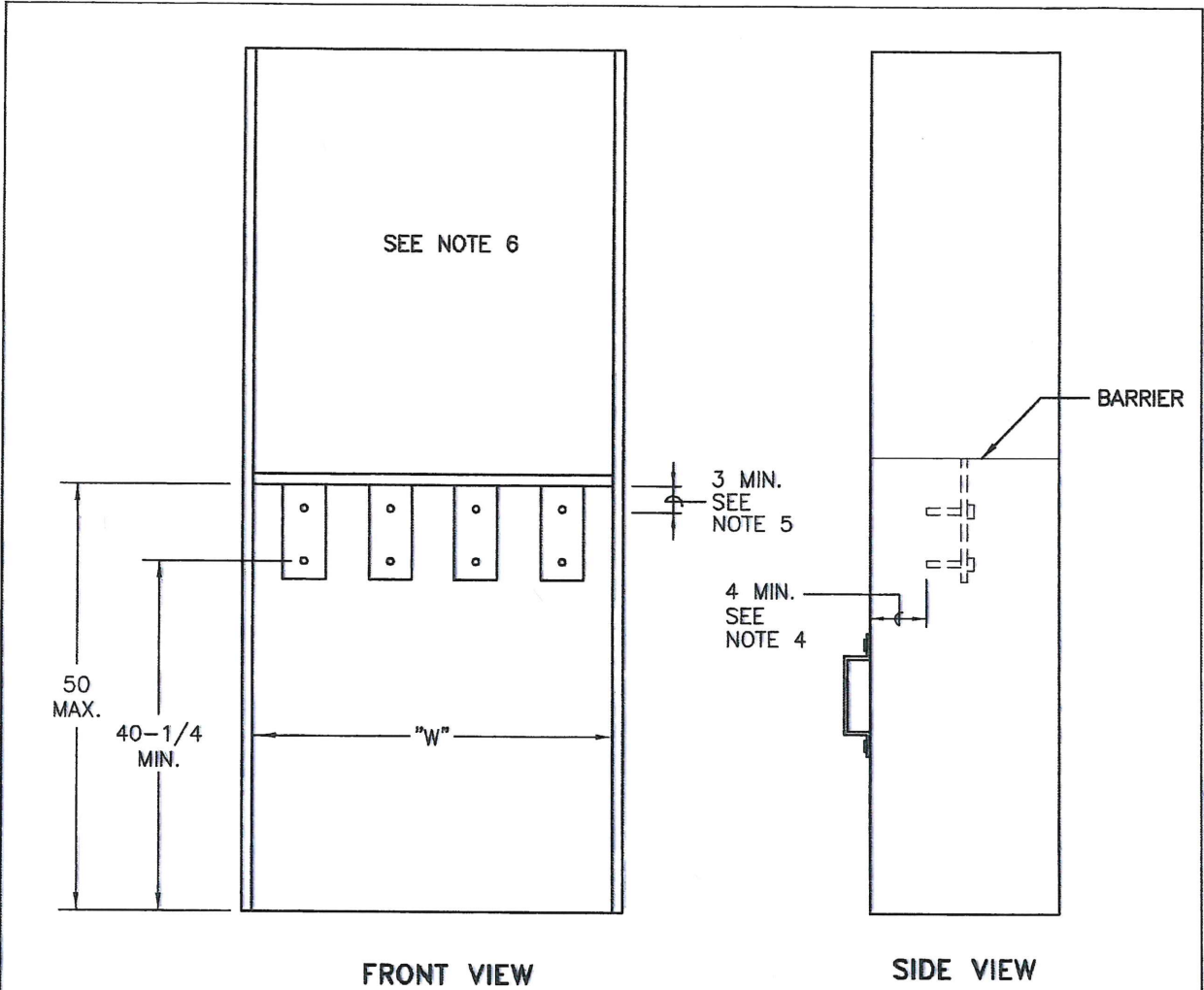

TABLE - MINIMUM DIMENSIONS

SWITCHBOARD RATING (AMPERES)	MINIMUM ACCESS OPENING DIMENSION (W) - SEE NOTE 8	
	3-WIRE	4-WIRE
BELOW 400	CONSULT SERVING AGENCY	
400 - 800	24	24
801 - 1200	24	30
1201 - 2000	30	35

NOTES:

1. The pull section may supply either a current-transformer compartment or a main service disconnect device.

ALL DIMENSIONS SHOWN ARE IN INCHES

REV.	DATE	DESCRIPTION
3	10/08	ADDED DIMENSION TABLE
SCALE N.T.S.	COMBINATION SWITCHBOARD SERVICE SECTION AND PULL SECTION 0 - 600 VOLTS, 2000 AMPERES MAXIMUM	
DATE 08/96	ELECTRIC UTILITY SERVICE EQUIPMENT REQUIREMENTS COMMITTEE	
		SHT 1 OF 2
		DWG NO. 327
		REV. 3

2. Pull section covers shall be:
 - a. Independent of other equipment and removable without disturbing adjacent panels.
 - b. Sealable, provided with two lifting handles, and limited to a maximum of 9 square feet in area.
3. The panel shall be equipped with terminating facilities complying with Drawing 347. Terminating facilities shall be secured to prevent misalignment and shall be rigid without the installation of current-transformers.
4. The clearance from the energized bus to the pull section removable access covers may be reduced if a safety barrier is provided by the manufacturer. For additional clearance and barrier requirements, see Drawing 347, Note 12.
5. A vertical clearance of 3 inches minimum shall be maintained between the centerline of the top bolts of the terminating facilities to any obstruction.
6. When the upper section is:
 - a. An instrument-transformer compartment, see Drawings 325 and 326 for additional service section requirements.
 - b. A main service disconnect device.
 - (1) A full width and depth, insulated, rigid barrier shall be provided to separate the pull section and main service disconnect compartment.
 - (2) The main service disconnect cover shall be sealable.
7. Sealing provisions for removable covers shall consist of two drilled stud and wing-nut assemblies located on opposite sides of the cover. Hinged covers shall be sealed on the unsupported side. See drawing 300, note II(i).
8. The minimum pull section access opening (W) is measured between the left side and right side return flanges.

REV.	DATE	DESCRIPTION		
2	08/96	DELETED CAPTIVE SECURING SCREW REQUIREMENT NOTE 14 - PROJECT #960202		
SCALE N.T.S.	COMBINATION SWITCHBOARD SERVICE SECTION AND PULL SECTION 0 - 600 VOLTS, 2000 AMPERES MAXIMUM		SHT 2 OF 2	
DATE 08/96	ELECTRIC UTILITY SERVICE EQUIPMENT REQUIREMENTS COMMITTEE		DWG NO. 327	REV. 2